

### TYPICAL PANEL FIXING ARRANGEMENT

CAD REF 100-1  
SCALE 1:25

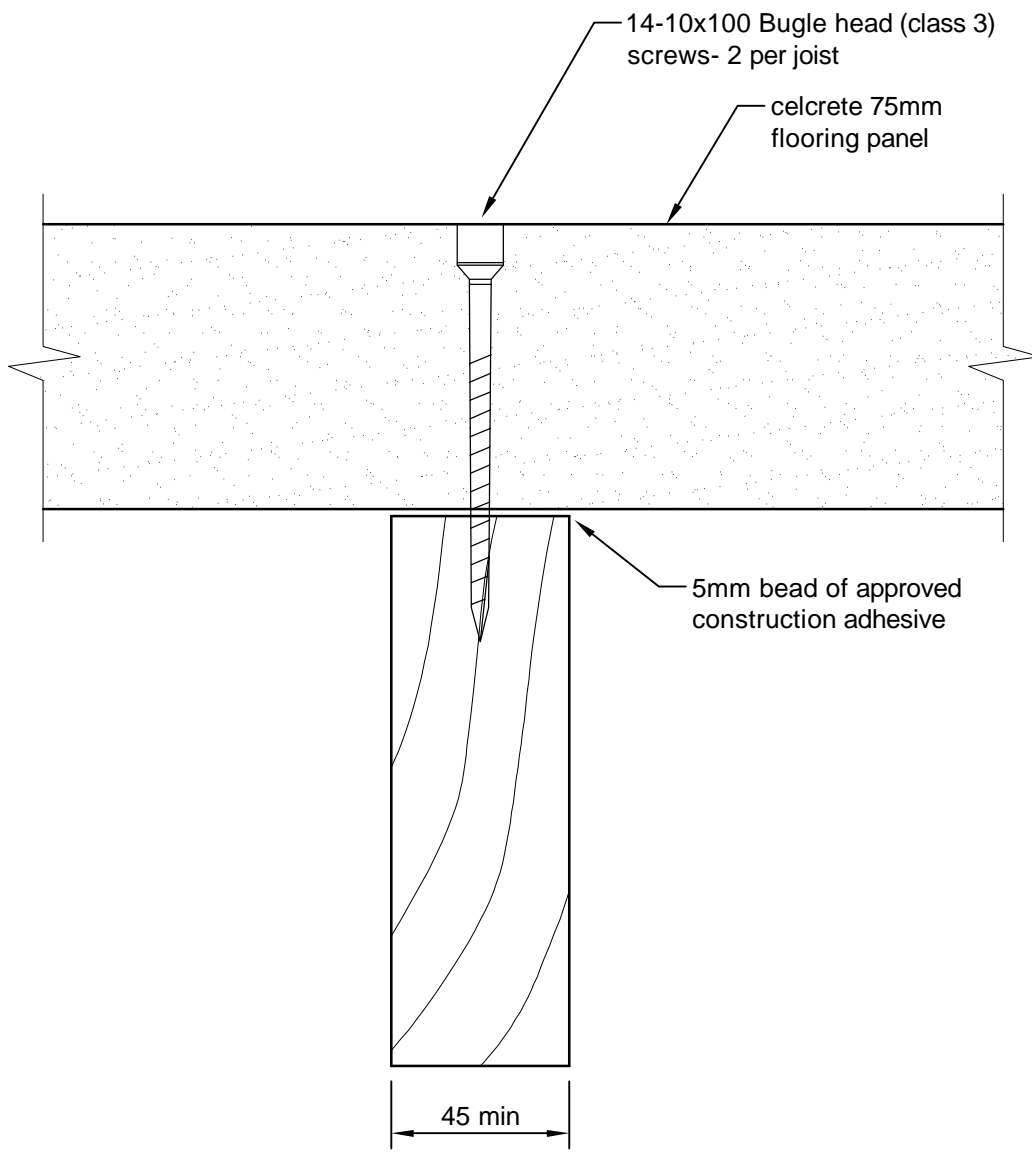

TYPICAL FLOOR JOIST FIXING - DETAIL 2

CAD REF 100-2  
SCALE 1:2

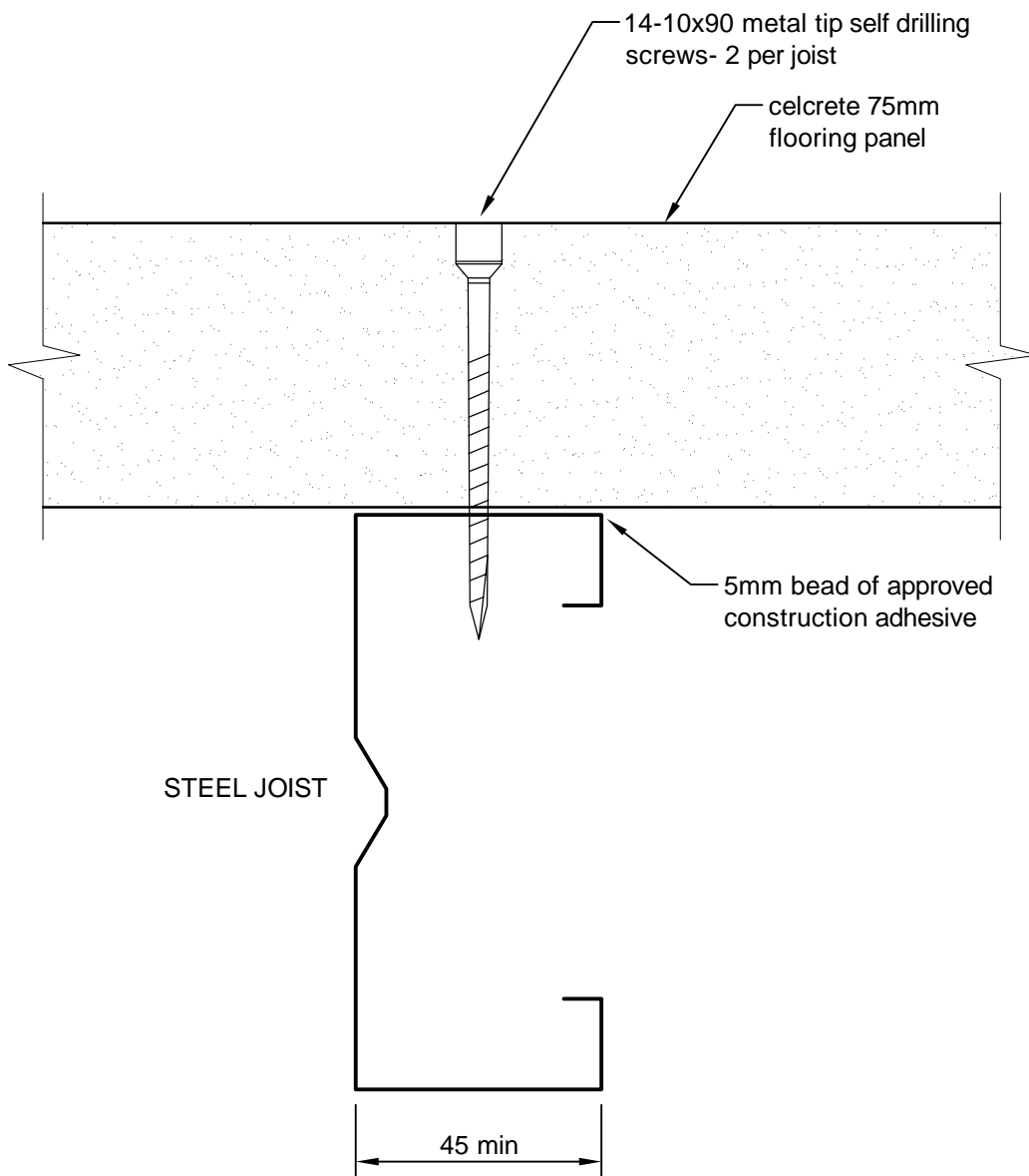

### TYPICAL STEEL FLOOR JOIST FIXING DETAIL 3

CAD REF 100-3  
SCALE 1:2

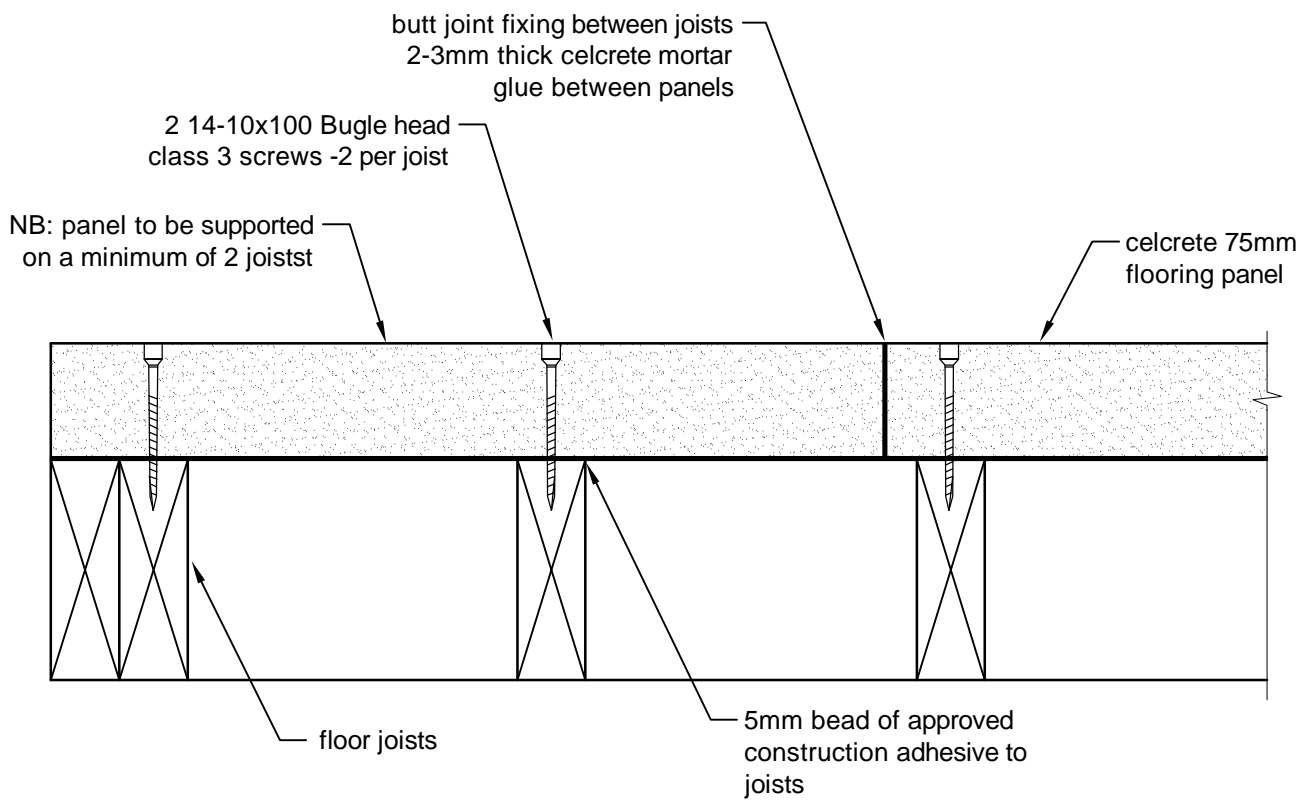

### SECTION THROUGH PANELS - DETAIL 4

CAD REF 100-4

SCALE 1:5

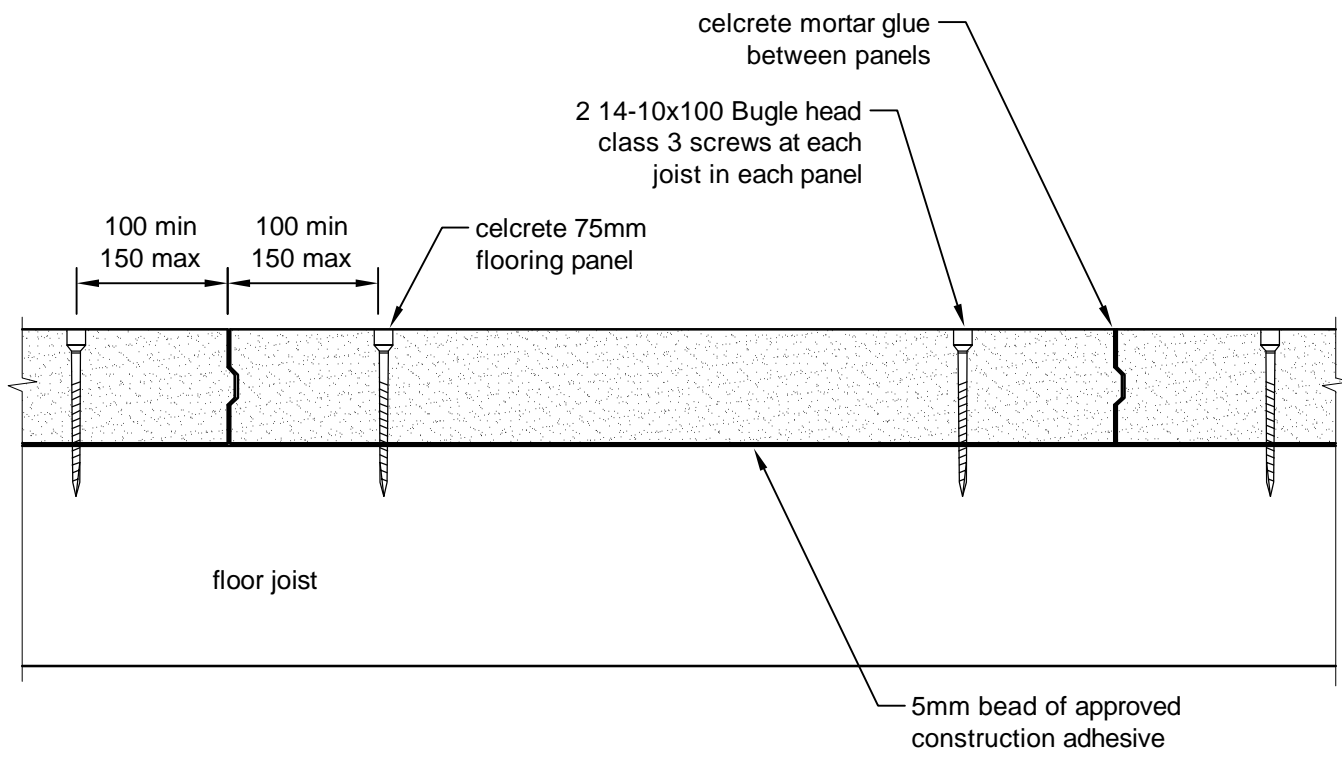

TYPICAL PANEL INSTALLATION - DETAIL 5

CAD REF 100-5  
SCALE 1:5

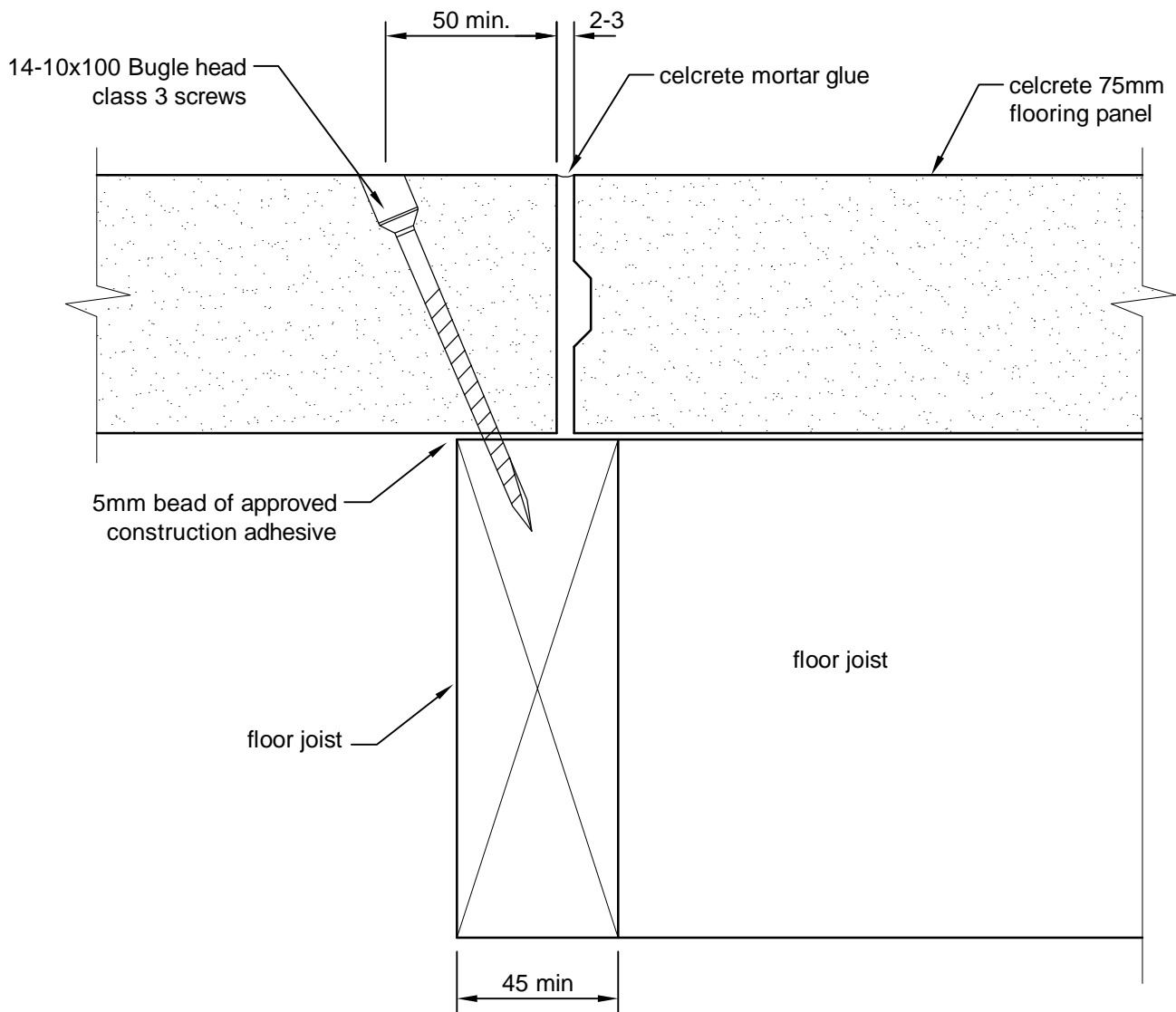

**TYPICAL FLOOR JOIST DETAIL  
CHANGE OF JOIST DIRECTION**

CAD REF 100-6  
SCALE 1:2

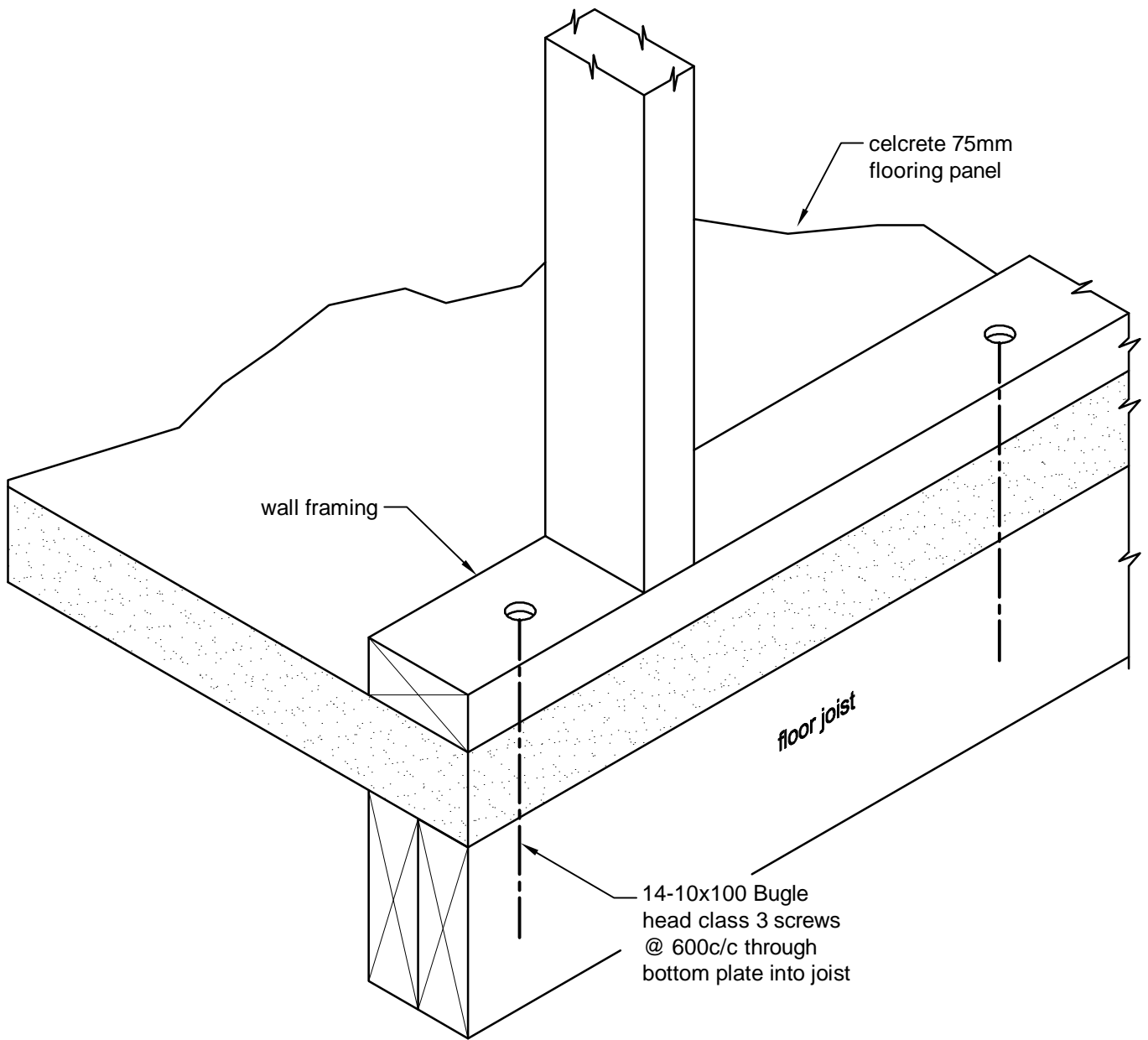

### TYPICAL WALL FIXING DETAIL

CAD REF 101-1

SCALE 1:5

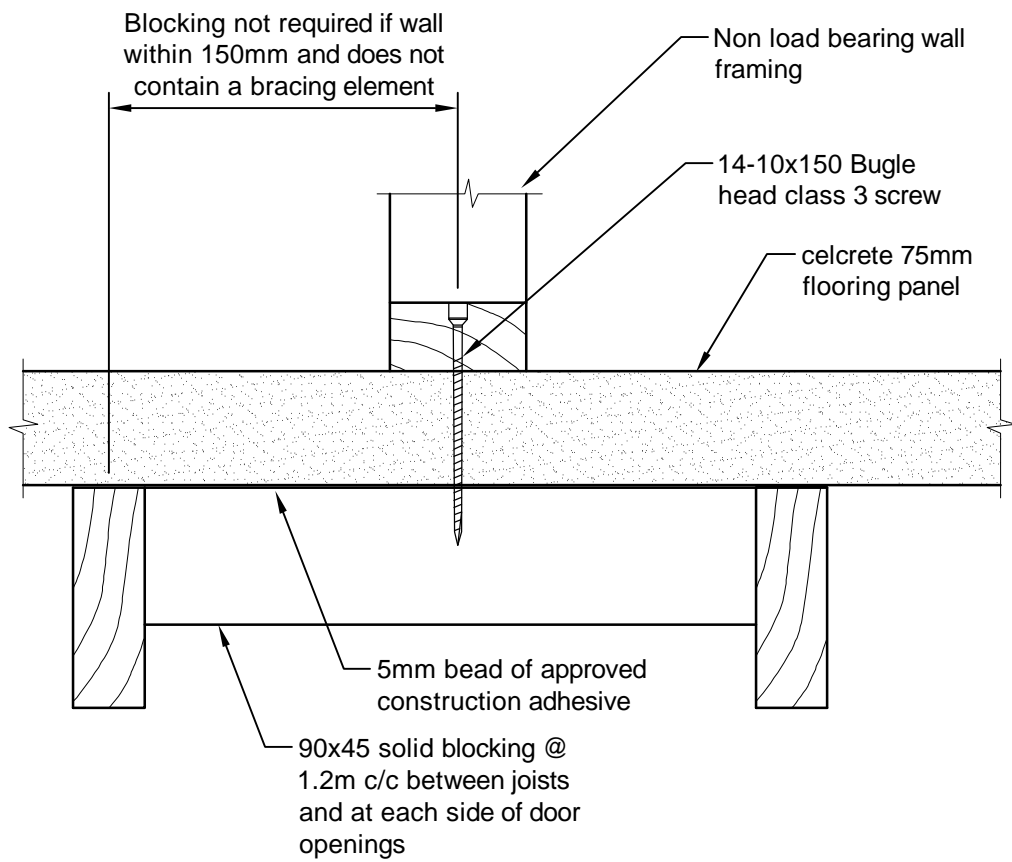

## NON LOADBEARING WALL DETAIL

CAD REF 101-2

SCALE 1:5

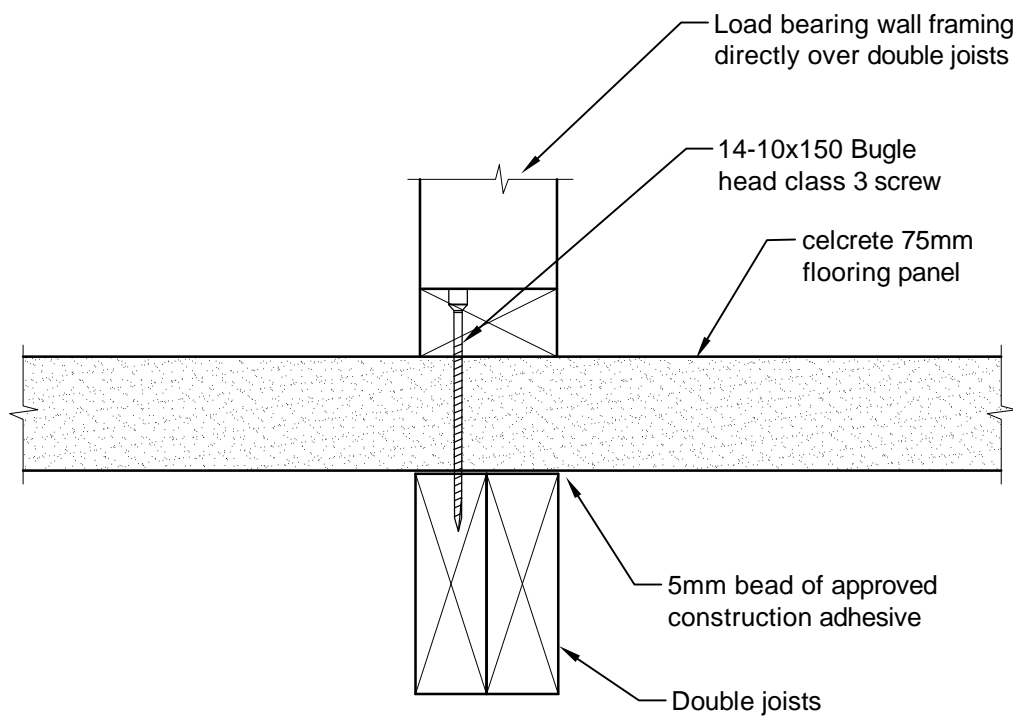

## LOADBEARING WALL DETAIL

CAD REF 101-3

SCALE 1:5

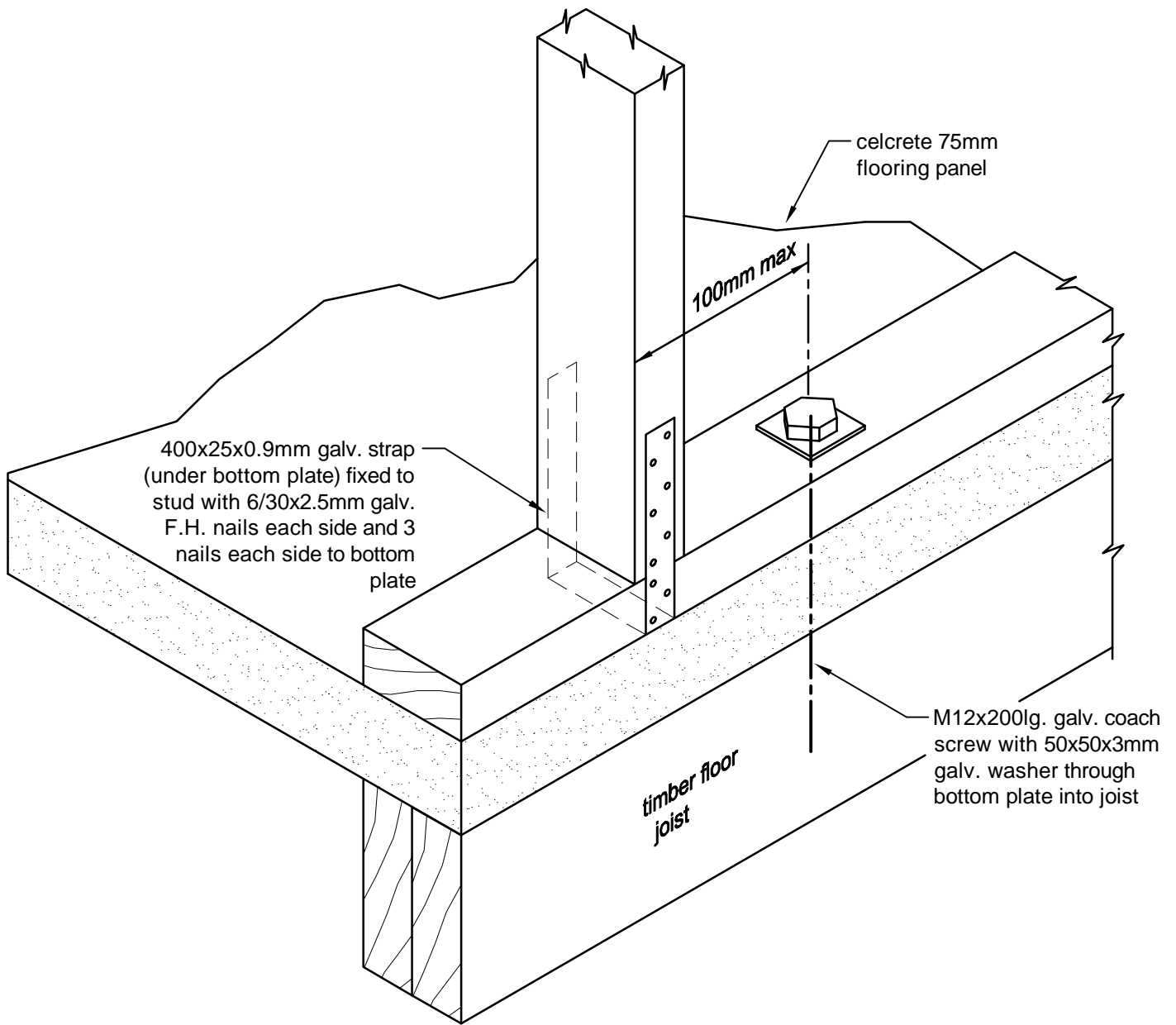

### BRACE WALL FIXING DETAIL

CAD REF 101-4

SCALE 1:5

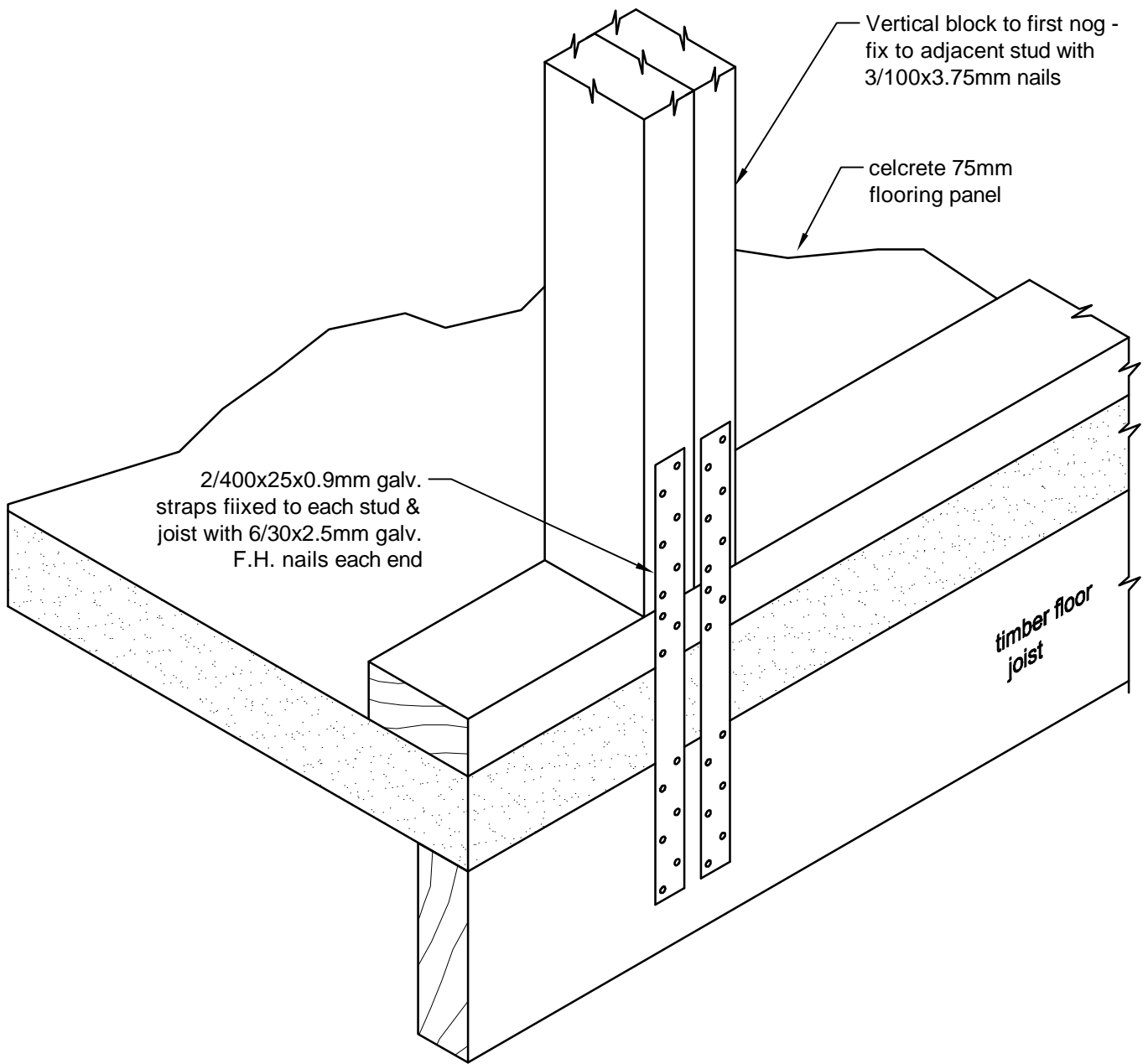

ALTERNATIVE BRACE WALL FIXING DETAIL

CAD REF 101-5

SCALE 1:5

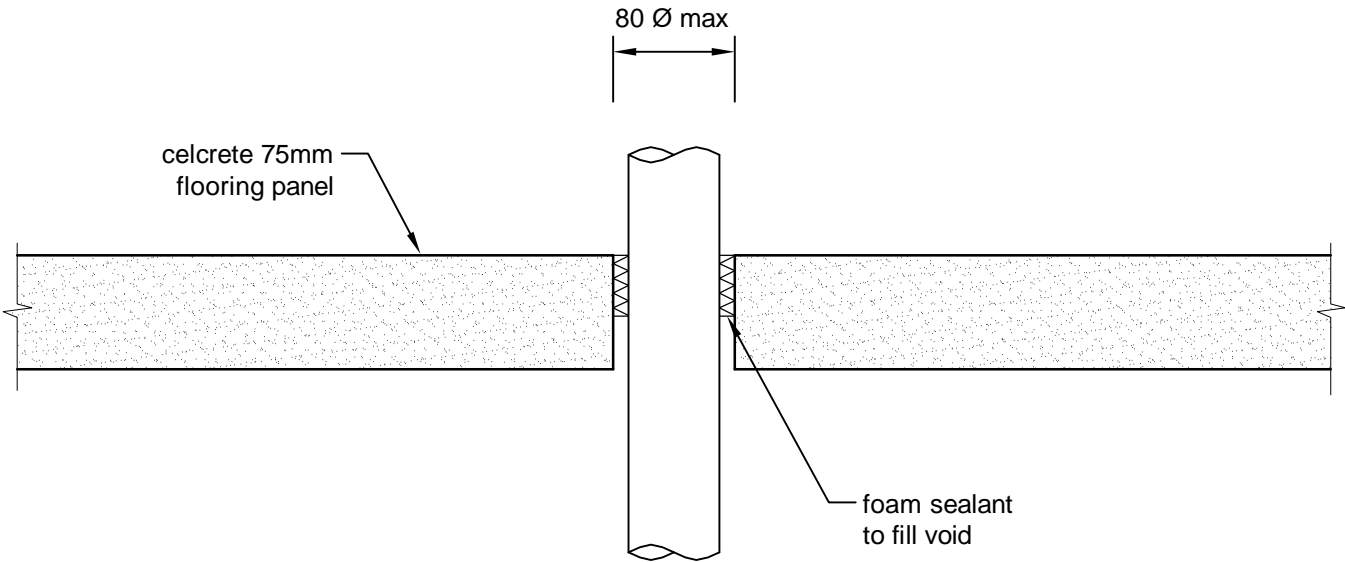

TYPICAL PENETRATION

CAD REF 102-1  
SCALE 1:5

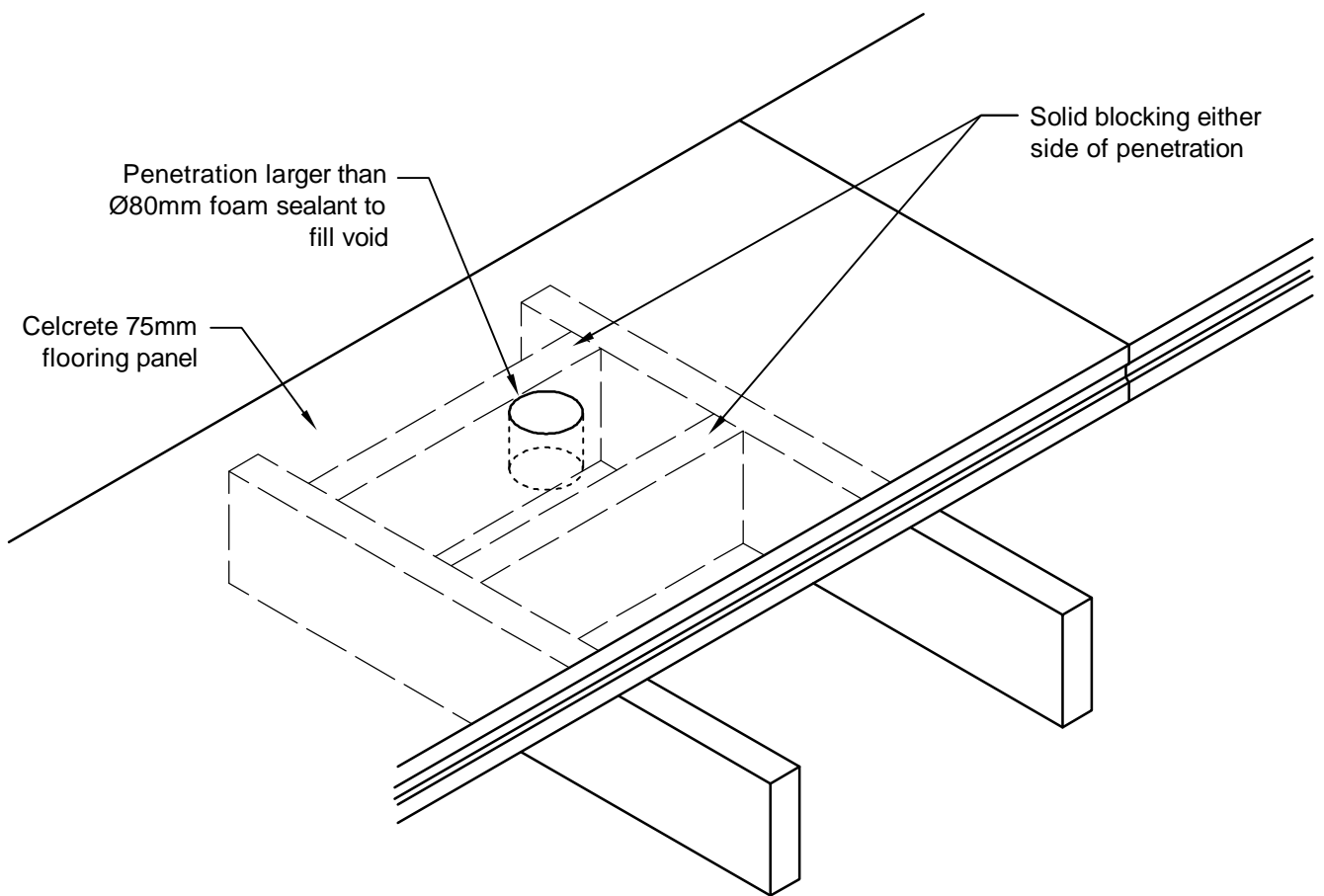

## TYPICAL LARGE PENETRATION WITH BLOCKING

CAD REF 102-2

SCALE 1:10

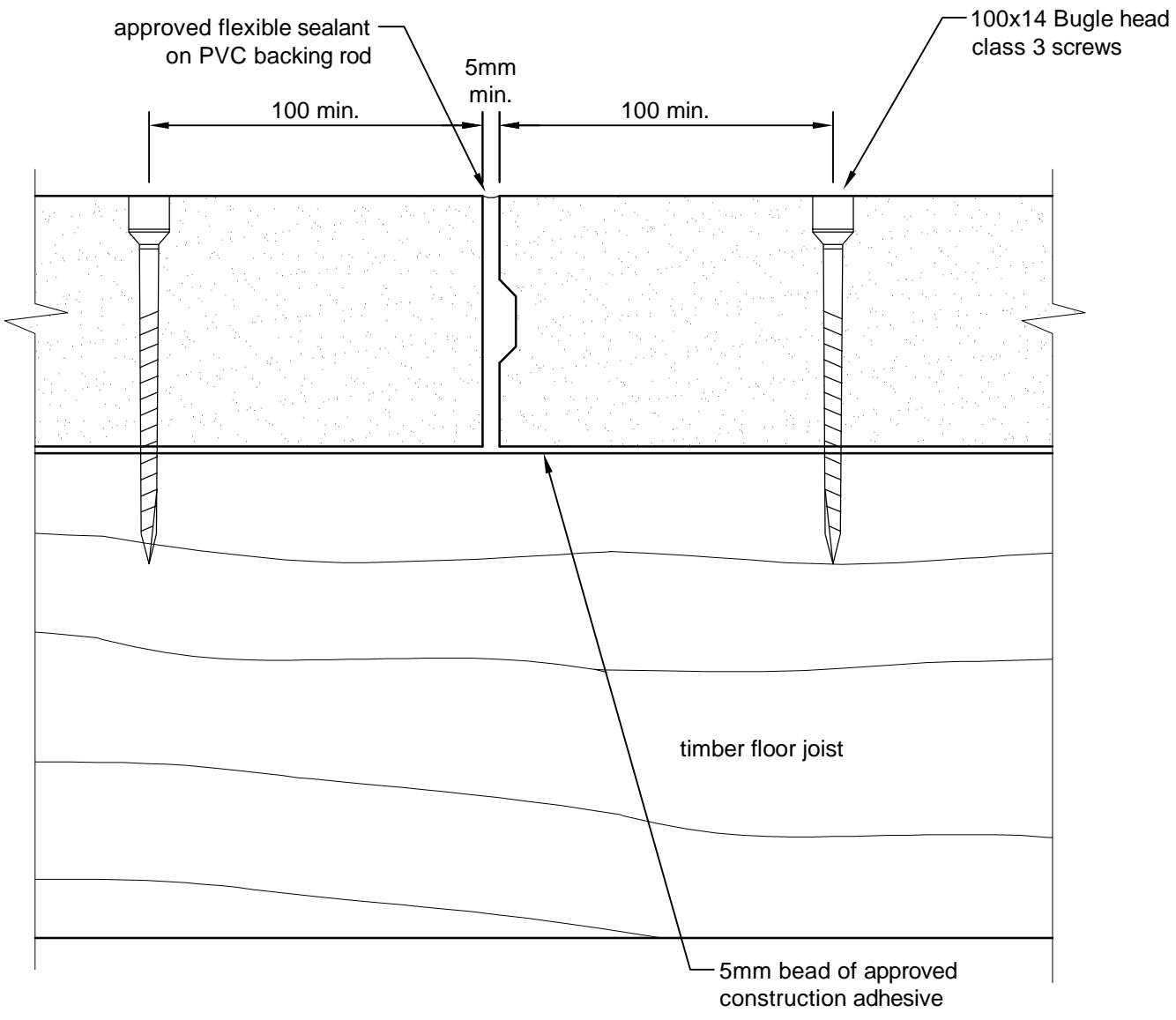

**TYPICAL CONTROL JOINT**

CAD REF 103-1  
SCALE 1:2